

## New Motion Control Approach Enhances Time To Market, Flexibility and Capability at Reduced Development Cost

By Ir. Arend-Jan Beltman and Ir. Rob Pulles, CCM Centre for Concepts in Mechatronics BV.

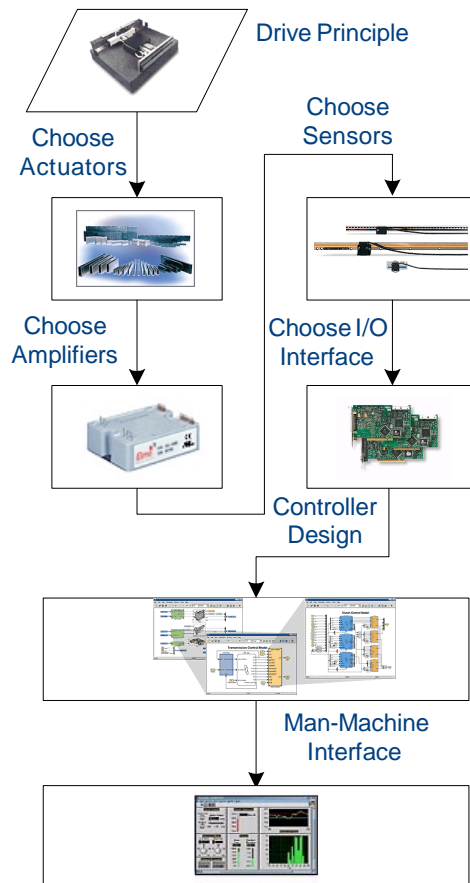

### Abstract

SAXCS is the new system control approach. It is hardware independent, flexible, and ideally suitable for small and medium sized series. Original Equipment Manufacturers can choose from many solutions to help them reduce cost of ownership for their customers. An increasingly popular solution is to make use of model based design of the control tasks in their equipment. Today's design tools allow complete simulation and testing of the control design before it is transferred automatically into an embedded design i.e. software code. CCM worked out this approach to an industrial level, with proven functionality, and a number of tested hardware components. This technique is now accessible to OEM companies that build small and medium sized series, so they can take advantage of the flexibility and hardware independency of the SAXCS approach, and profit from development cost reduction, hardware cost reduction, and faster time to market.

## Introduction

The role of control technology in machine development is ever increasing. Its applications can be found in different disciplines, such as in motion, thermodynamics and optics control. Whereas motion control was formerly used to realize a movement, it is now becoming an approach which applies, together with the motion, (alignment) error corrections and which influences the machine behavior (dynamics) in an intelligent way. Thanks to this approach, errors caused by production tolerances or limited frame rigidity can be compensated without the use of minute adaptation methods and expensive redesign. More so, control systems are becoming intelligent and self-learning and are able to adapt their behavior according to the process conditions. One example is the (quasi-static) filters by means of which very specific natural frequencies within the machine can be suppressed, so that these frequencies do not hamper the process.

Because of this trend, the importance of integrated problem solution is increasing as well. Designers need to be able to communicate beyond the boundaries of their own field and to create multi-disciplinary solutions, driven by cost effectiveness and time-to-market. Especially machine dynamics are becoming more and more integrated with motion control. Because of their limitations, existing hardware solutions for control systems do not optimize this integrated problem solution.

OEM companies that apply control systems in their products are increasingly facing the short lifecycles of motion control parts. As such, component suppliers also need to respond faster to market demands and, as a consequence, components go obsolete at a much earlier stage. For OEM companies, this means they need to redesign to be able to apply the new hardware, which often does not come cheap.

## Increasing Demands

As a system developer, CCM experiences the direct consequences of these trends. Customers wish to achieve solutions in a quicker and less expensive way. Product costs need to decrease and performance needs to increase. More so, customers do not want to depend on only one hardware supplier.

The demands the controller faces because of the growing integration of intelligent functions, can often not be fulfilled by available controllers. Their architecture simply is not flexible enough to integrate all required intelligence.

At the same time, we see that the available controllers often are equipped with a fixed set of functions which in many cases are superfluous (i.e. superfluous I/O) but which are paid for nonetheless. These disadvantages can now be canceled by means of SAXCS.

## A Brief Look Back

In a classic control architecture one often sees a controller-amplifier-actuator. Often all parts must be supplied by one source for proper (co)operation. However, these controllers supply standard solutions for standard problems. With the growing demand for control technology, as explained above, the existing standard controllers hardly permit easy and quick tailor-made solutions. They often provide extensive functionality but not, however, the solution the application requires. Their architecture for control technology is often rigid which complicates the embedding of extra demands.

Therefore, CCM has developed an approach which bypasses the disadvantages of standard controllers and which saves development effort and hardware costs at the same time. Furthermore, this approach provides a diagnostic functionality with countless possibilities.

## How it works

Smart And FleXible Control Solutions is the answer CCM provides to the above-mentioned market demands. Tailor-made functionality, precisely up to the task, at the lowest possible price and a MUST for short development times.

SAXCS combines state-of-the-art design tools (The Mathworks [2]) with standard hardware (processors and industrial PCs), resulting in a fully open architecture with a high flexibility and fully functional transparency. The configuration thus created, is built up completely from standardized components. In other words: one can choose from many hardware providers without the need for specific adaptation of the controller hard- and software.

CCM has been able to develop this approach from theory into reliable working solutions, thanks to our in-depth know-how and experience in machine dynamics and control technology.

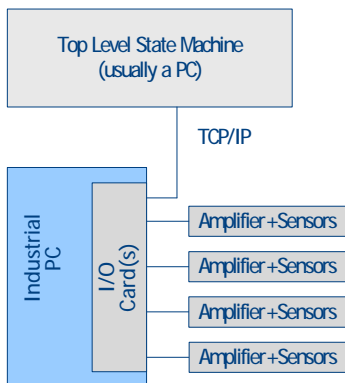

Figure 1 '4Motion' topology

CCM has developed different HW topologies for SAXCS. The '4Motion' approach applies a VHDL programmable I/O card, which offers program flexibility down to the nanosecond level. Hence ultra fast control (sample times up to 200 kHz) is possible. High speed (10MHz range) interpretation of front end signals (like e.g. interpolation of SIN/COS signals) is made easy.

The interface with the top level control unit of the equipment goes via TCP/IP and a DotNet socket that is usually part of a labview application.

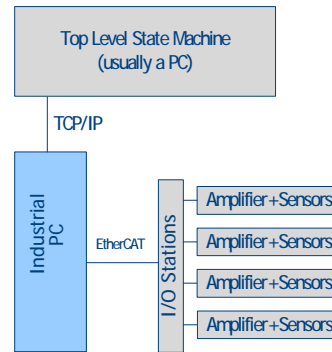

Figure 2 'Emotion' topology

CCM can expand the I/O needs by adding an industrial ultra high speed bus system called EtherCAT. Thus different Beckhoff I/O types (terminals) can be added easily to the real time control loop. In the same way EtherCAT servo amplifiers can be hooked up too.

## Solid Tool

CCM has chosen MATLAB-SIMULINK of The Mathworks as the tool by means of which controllers can be built. MATLAB-SIMULINK is known and accepted worldwide. It stands for countless man-years of design work offered in the shape of modular building blocks with reliable functionality and excellent software support. The Mathworks supports a large number of hardware components such as different brands of processors (e.g. TI and Motorola) as well as many PC platforms. The use of Mathworks tools enables easier communication with the customers' technicians, as there is no longer a need to know the very specific features of the controllers.

## SAXCS pays off

SAXCS completely fits into the trend to decrease development and production costs. During the concept and design phases, the design can already be validated by means of simulations. This is a tremendous advantage; Considerable time can be saved as design errors are retrieved and solved at a very early stage. After this iterative process, the software code can be generated fully automatically to run on the hardware topology.

This is a second important advantage of SAXCS. Then, the so-called 'pre-integration phase' follows. All servo axes are in simulation mode which enables the software engineer who is responsible for the highest control levels to start testing at an early stage! In case design modifications are still necessary during the (hardware) integration phase, this can be quickly realized because the code generation phase is done fully automatic and hardly any extra costs are involved. This is a third advantage of the SAXCS approach. In time, CCM has composed a simulink architecture that allows easy reusability of functionality. Figure 3 depicts a schematic view of the development flow [1].

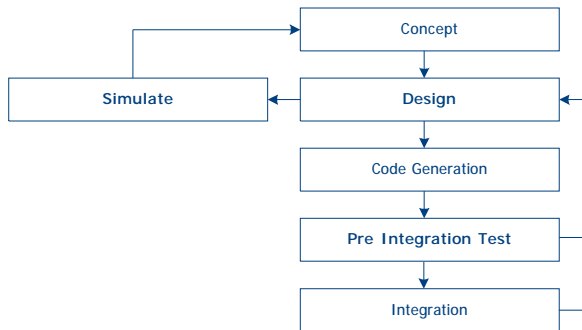

Figure 3 Development flow in SAXCS

The completely free configurability also means that the superfluous functionality that is present in many controllers no longer needs to be paid for. Think for instance of I/O's, of which one receives too few or too many, but never the number that is fit for the job. With SAXCS, exactly enough I/O's are installed, not more, not less. The sum of hardware costs for control, amplifiers and I/O already reaches a competitive level when the number of motion axis is 4 or more.

## Examples

At CCM, many multiple-axis systems are developed. Thanks to SAXCS, numerous control solutions have been realized.

### Example 1:

The possibilities to exceed the boundaries in the field of control technology are shown in the case of a manufacturer of industrial printers.

This company wished to enhance the performance of an existing model, illustrated in subsequent figure.

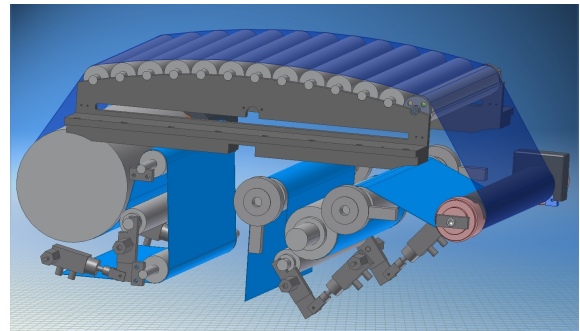

Figure 4 Substrate path of industrial printer

First, by means of measuring, all possible solutions were analyzed with the help of SAXCS. This investigation resulted in a dynamic model of the substrate path in terms of a lumped mass representation.

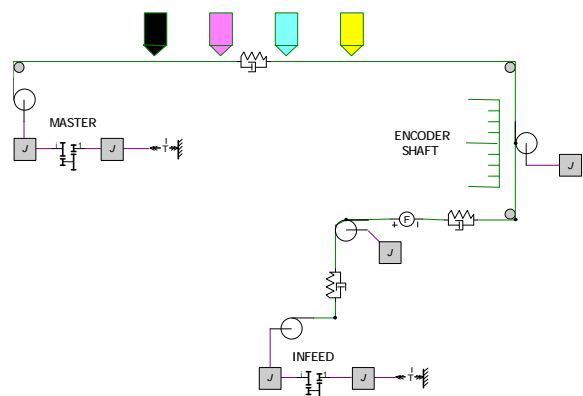

Figure 5 Lumpedmass model of substrate path

In figure 6 is illustrated the impact of different substrates on loop-gain properties of the controller. The red circled area shows strong variations. So it appeared that substrate dependent controller adjustment could significantly improve the performance!

By selecting the dedicated I/O cards and a rugged industrial PC, CCM arranged a hardware configuration that could introduce an upgrade for both new machines as well as installed base. A dedicated controller was designed using Mathworks tools. Finally a dedicated man-machine-interface was composed for diagnostic means such as identification of different substrates. (figure 7)

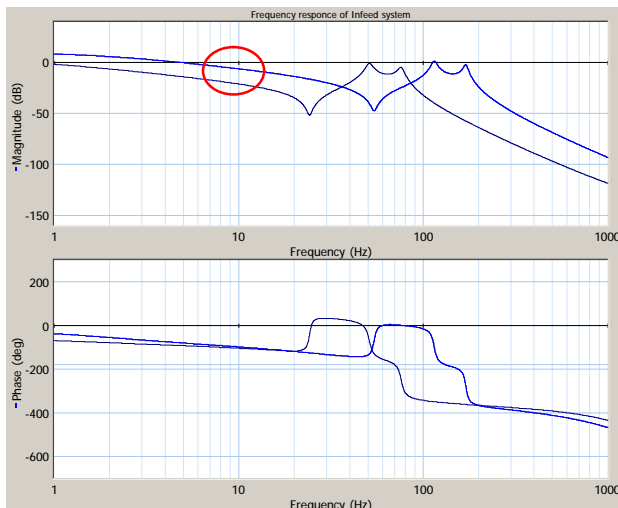

Figure 6 Dynamics of 2 different substrates

During the project, strong analytical and diagnostic tools of CCM were applied. At the end of the investigations, a subset of those could directly<sup>1</sup> be applied to compose an autonomous executable. This program enables operators to find the right controller setting almost instinctively. A mini-course in controller design was sufficient to make them do the job!

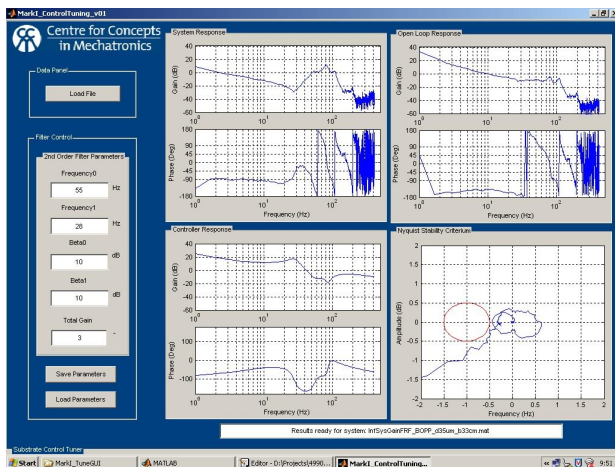

Figure 7 Strong diagnostic tool

So by doing it the SAXCS way, it appeared that CCM improved functional performance by a factor of 5. Analytical expertise in machine dynamics and control has been successfully transformed in a viable solution!

**Example 2:**

Singulus Mastering is worldwide supplier for mastering equipment for DVD and Blu-ray discs.

<sup>1</sup> Transformation to another programming language was not necessary

The latest generation laser beam recorder, has been co-developed in a short period of only 18 months.

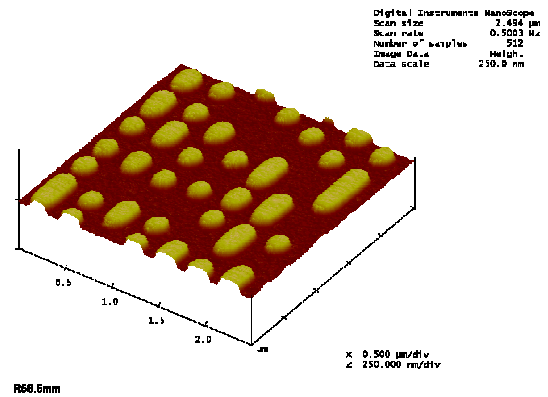

Figure 8 Pitch visualization Blu-ray

Apart from the challenges to minimize non-repetitive radial errors, the imaging process required only a few nanometers tracking performance of the focus lens, whilst writing the track moving with 120 [km/h]. The '4Motion' concept of CCM enabled Singulus Mastering to implement so called learning feedforward technology.

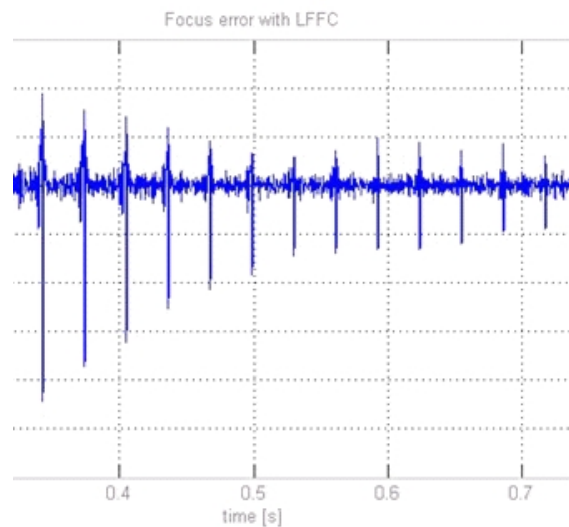

Figure 9 Impact of 'learning' control

The technology is known in the academic world for many years and now accessible for industry through SAXCS! The solution is so called 'add-on' and has been applied in prior generation mastering equipment too.

### Example 3:

Advanced Laser Separation International (ALSI) is supplier of laser dicing equipment using a patented multiple laser beam technology. The latest generation is prepared for 12-inch wafers, in particular those used in the semicon memory market.

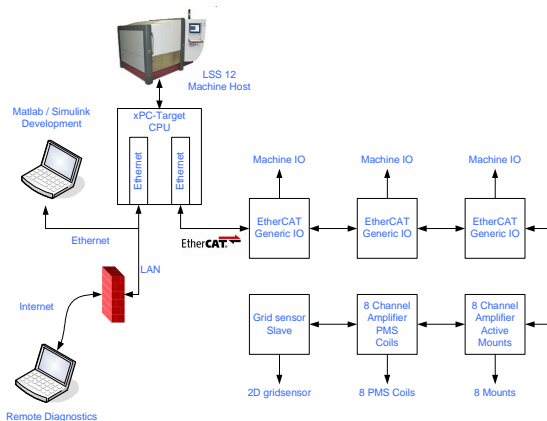

Figure 10 'Emotion' topology ALSI

CCM had to face several mechatronic challenges. Amongst them was a 6 month development period and significant reduction of Cost of Goods (CoG).

The unorthodox controller architecture of the planar motion system was composed using Matlab-Simulink. By using EtherCAT bus, we could keep a centralized way of controller implementation, whilst avoiding cabling issues and/or signal integrity problems. In this way the code generation tools of The Mathworks were literally exploited. The centralized approach (through EtherCAT) introduced a significant cost advantage since all motion control tasks were running on a single (regular) industrial PC!

### SAXCS in a nutshell

- Independent of hardware suppliers (Less risk of obsolete components)
- Standardized controller interface (No costly interfacing development)
- Reusable (advanced) control blocks (Mathworks software libraries)
- Flexible control design (Tailor-made solutions)
- Development time reduction (Cost saving and time-to-market)
- Straightforward controller description (facilitates communication)
- Smart (Enables non-standard control architectures)

### Who we are?

CCM is an independent research and development company, founded in 1969 by professor Alexandre Horowitz. CCM has a long experience in inventing original concepts but is also capable of realizing the entire development process up to a finished product or installed production equipment. CCM integrates know-how in the fields of mechanical engineering, (opto-)physics, electrical and electronic engineering and information technology.

Development is done by CCM in a professional way, which enables us to control the costs for realizing functionality, performance and time to market.

CCM aims at a win-win situation, by building a strategic business relationship through intensive knowledge exchange.

CCM stands out thanks to a special know-how in the following areas;

- Machine dynamics with related control technology, specifically for fast and precise positioning and handling.
- 'Mechanical-photonics'; the design and realization of critical optical measurements
- Energy storage systems on the basis of fast rotating flywheels

CCM focuses on the following market areas:

- Semiconductor industry
- (bio-)medical/pharmaceutical industry
- Printing/imaging
- Aerospace
- Energy storage/electric drives

Mainly our customers are OEM companies such as: ASML, BESI, PamGene, Organon, AKZO, Océ, AGFA.

### How to contact CCM

CCM Centre for Concepts in Mechatronics BV  
De Pinckart 24, NL – 5674 CC Nuenen  
Phone: +31 (0)40-263 50 00  
Fax: +31 (0)40-263 55 55  
Website: [www.ccm.nl](http://www.ccm.nl)

### References

- [1] Cracking the code automatically, Jim Ledin & Mike Dickens, Electronic Design Europe, June 2005.
- [2] [www.MathWorks.com](http://www.MathWorks.com)